

Biosolar photovoltaic mounting system

BauderSOLAR F XL (with waterproofing system)

BauderSOLAR F XL is designed to be installed on specific Bauder bituminous or single-ply waterproofing systems and provides a lightweight, zero penetration and quick to install mounting solution for framed solar modules.

	Product name	Function	Thickness (Approx.) (mm)	Weight (Approx.) (kg/m ²)
1	Solar Module	Framed crystalline solar photovoltaic module	Variable	
2	BauderSOLAR F XL	Mounting unit	1550 x 340 x 310	4.8
3	BauderSOLAR GF & BJT	Baseplate and bayonet cap	280 x 100 x 35	0.2
4	BauderSOLAR MST	Welding sleeve	440 x 260 x 5.2	variable
5	BGTRS System	Warm roof waterproofing system	Variable	Variable

In-depth and up-to-date product specific technical data is available for each element within a system.
Download from our website bauder.co.uk/technical-centre

F XL mounting & Warm roof indicative build up

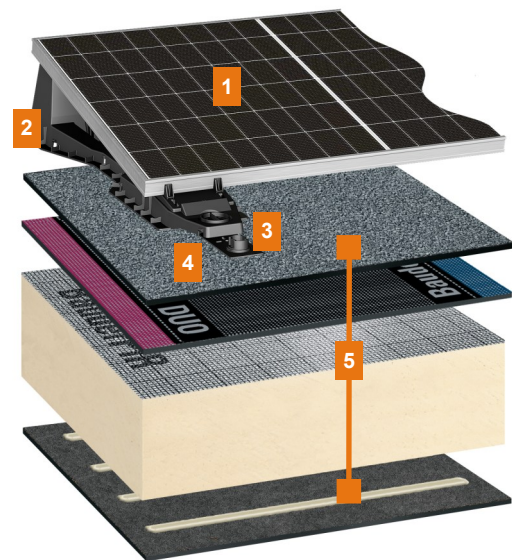

Characteristics of the system

- Penetration and ballast-free installation method reduces risk
- High output-to-roof-space ratio
- Lightweight system 14-15 kg/m², depending on module selected and system layout
- Single source for integrated design of waterproofing and PV
- Our guarantee offer is clear and concise covering what is included/not included along with the conditions of the guarantee. A sample guarantee for this system is available on request.

- PTO for BauderSOLAR F XL mounting systems only

Biosolar photovoltaic mounting system

BauderSOLAR F XL (mounting system only)

BauderSOLAR F XL is designed to be installed on specific Bauder bituminous or single-ply waterproofing systems requiring zero penetration.

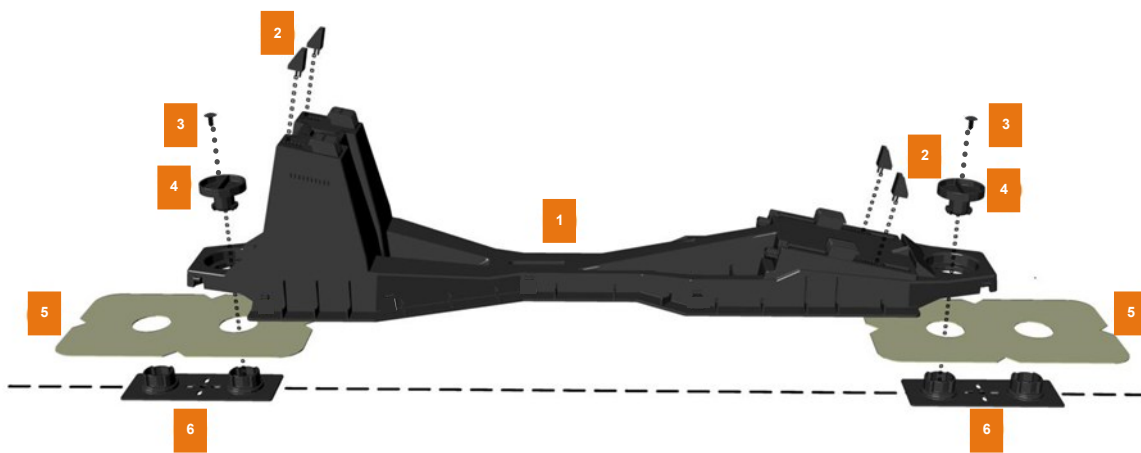

	Product name	Function	Quantity	Weight (Approx.) (kg/m ²)
1	BauderSOLAR F Main Substructure	Mounting unit with integrated module clamps	1 Piece	4.8
2	BauderSOLAR MDS Locking Pin	Module securing device with two snap-in hooks below (Polypropylene PP)	4 Pieces	
3	BauderSOLAR BSP Bayonet Safety Pin	Bayonet locking pin (Nylon)	2 Pieces	
4	BauderSOLAR BJT Bayonet Cap	Twist lock for locking into the base plate	2 Pieces	
5	BauderSOLAR MST Welding Sleeve	Welding sleeve for welding to Bauder bitumen and single ply roof membranes	Subject to design	
6	BauderSOLAR GF Baseplate	Receivers for the bayonet twist lock fitting	Subject to design	
Weight per mounting unit (Depending on PV module)				14-15 kg/m²

The system has variations available to the specifier so that a tailored solution meets the needs of the building. **The selection of products should be confirmed with our technical department to ensure suitability for the individual construction requirements of the flat roof.**

E: technical@bauder.co.uk

T: 01473 257671